

UTA Board of Trustees Meeting

February 13, 2019



Call to Order and Opening Remarks



Pledge of Allegiance



Safety First Minute



Turn off you vehicle's cruise control
so **YOU** are in control of your vehicle.



Recognition of UTA Operator Shelly Monson



Public Comment Period



Public Comment Guidelines

- Each comment will be limited to two minutes per citizen or five minutes per group representative
- No handouts allowed



**Approval of
February 6, 2019
Board Meeting Minutes**



Recommended Action (by acclamation)

Motion to approve



Agency Report



R2019-02-01 Authorizing Execution of an Interlocal Agreement – Multi-Jurisdictional Mutual Aid Agreement for Sheriff and Police Services



Recommended Action (by roll call)

Motion to approve R2019-02-01:

Authorizing Execution of an Interlocal Agreement – Multi-Jurisdictional
Mutual Aid Agreement for Sheriff and Police Services



Pre-Procurement Update

- a. Development of 3900 South Meadowbrook Station Property
- b. Corporate Sponsorship and Naming Rights Program Consultant



Discussion Items



Government Relations Update

UTAH TRANSIT AUTHORITY



UTA Advertising Campaign Preview

UTAH TRANSIT AUTHORITY





UTA



2019 Campaign

Campaign Purpose

UTA is driven to continuously improve Utah's transportation through dedicated employees, enhanced service, innovative mobility solutions, reduced congestion, and clean air.

It's a new day at UTA.

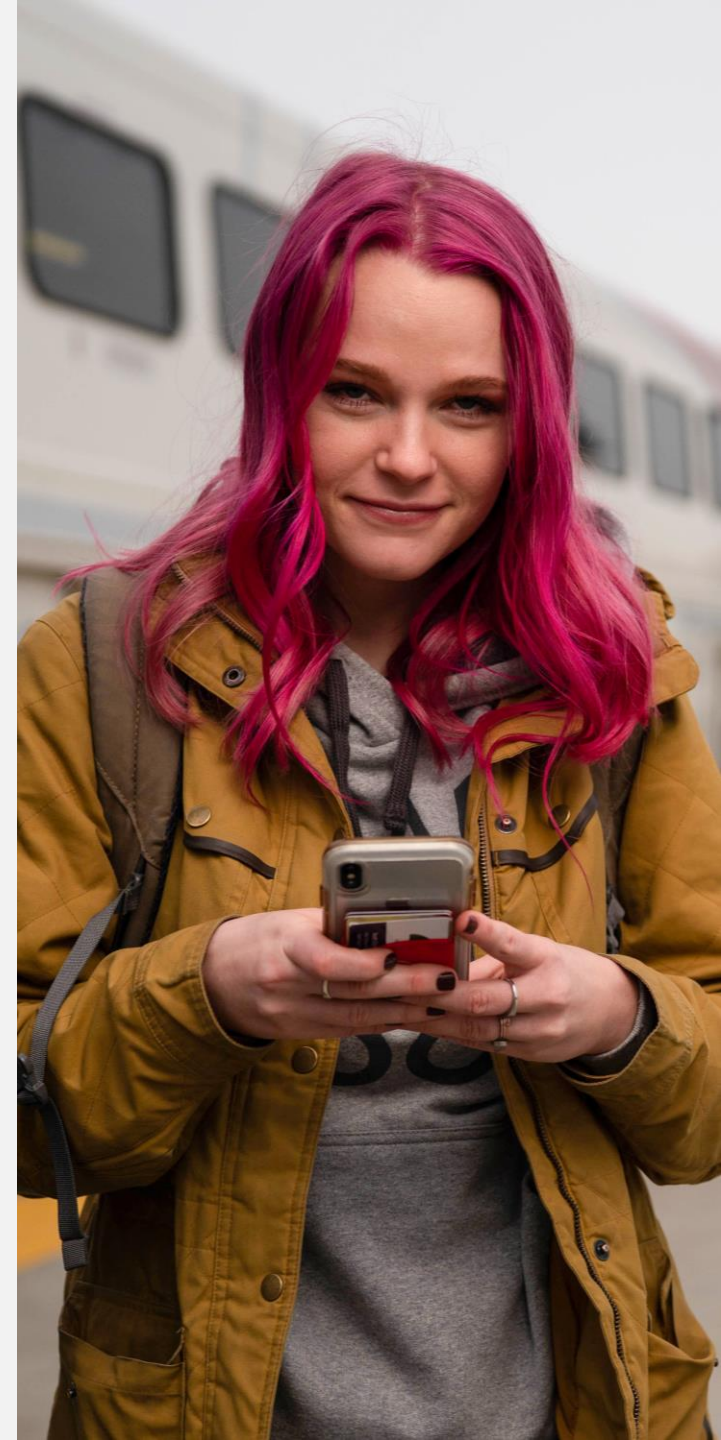

Campaign Goals

ACCOUNTABILITY

Reinforce our focus on the rider and their transportation needs, as well as demonstrate to the general public that UTA is part of the fabric of our community.

PEOPLE

Highlight our commitment to riders, as well as the UTA employees who are dedicated to providing great service every day.

RIDERSHIP

Encourage ridership by promoting the breadth of UTA's various services, and by reinforcing the benefits of transit to the community.

- Clean air
- Reduced congestion
- Enhanced mobility



UTA isn't just a transit system. It's part of the Wasatch Front's identity.

We aren't just trains and buses; we're part of something much larger. We're your neighbors, working every day to connect people, strengthen communities, and improve our quality of life.

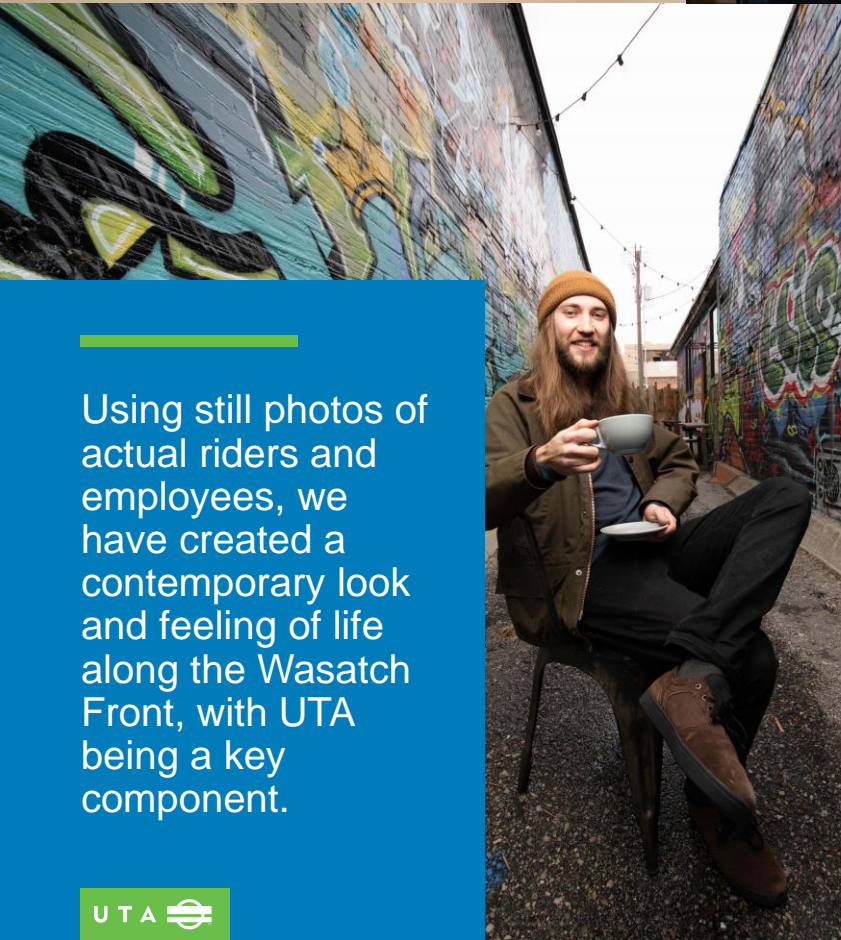

Using still photos of actual riders and employees, we have created a contemporary look and feeling of life along the Wasatch Front, with UTA being a key component.

300 North

298 N. University Ave.



DOUGH

AFFORDABLE

SOUVENIRS

DOUGH
Nation

SOUVENIRS

IBERICA





Thank You

UTA 

Service Planning Implementation Process



UTA Planning Process

and

Service Planning Toolbox



UTA Service Planning Policy

UTA Service Planning and Implementation Process

UTAH TRANSIT AUTHORITY

Strategic Planning Service Planning Operations Planning Implementation

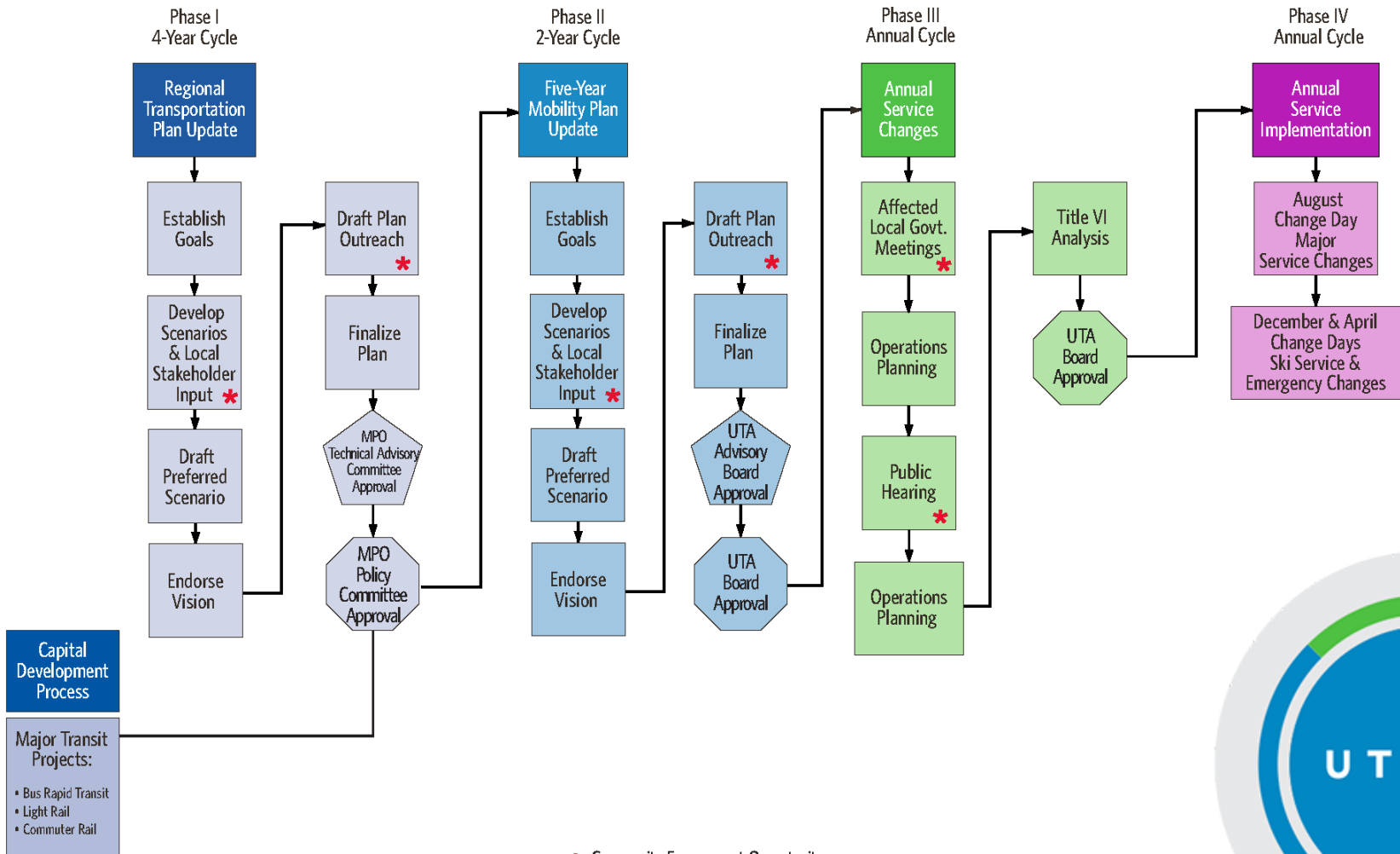

Phase 1 – Regional Transportation Plan

Strategic Planning

UTAH TRANSIT AUTHORITY

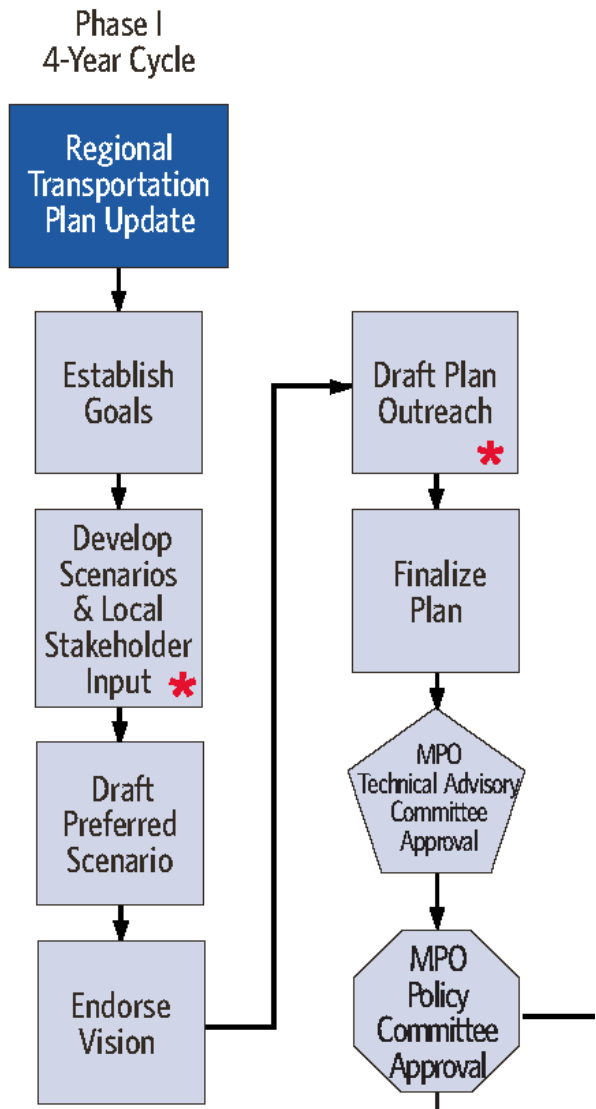

Phase 2 – Five-Year Mobility Plan

Service Planning

UTAH TRANSIT AUTHORITY

Phase II
2-Year Cycle

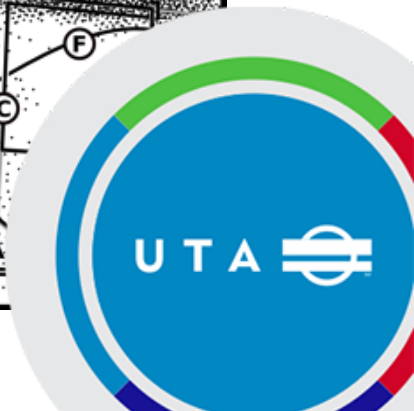
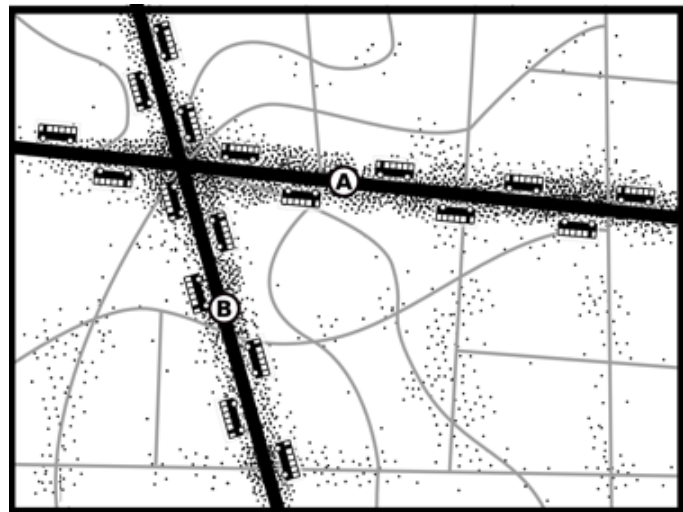
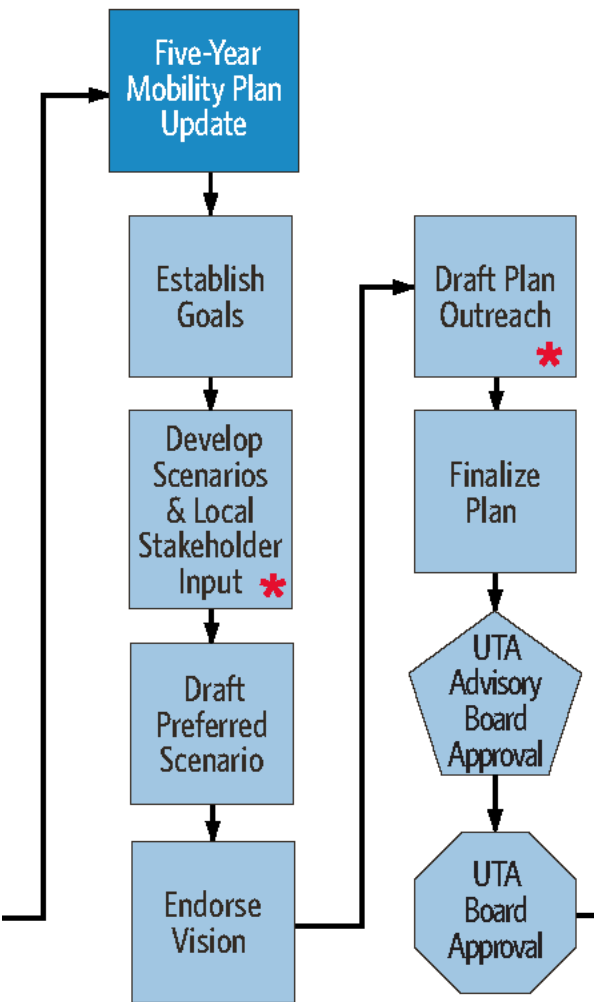

Phase 3 – Annual Service Change Process

Operations Planning

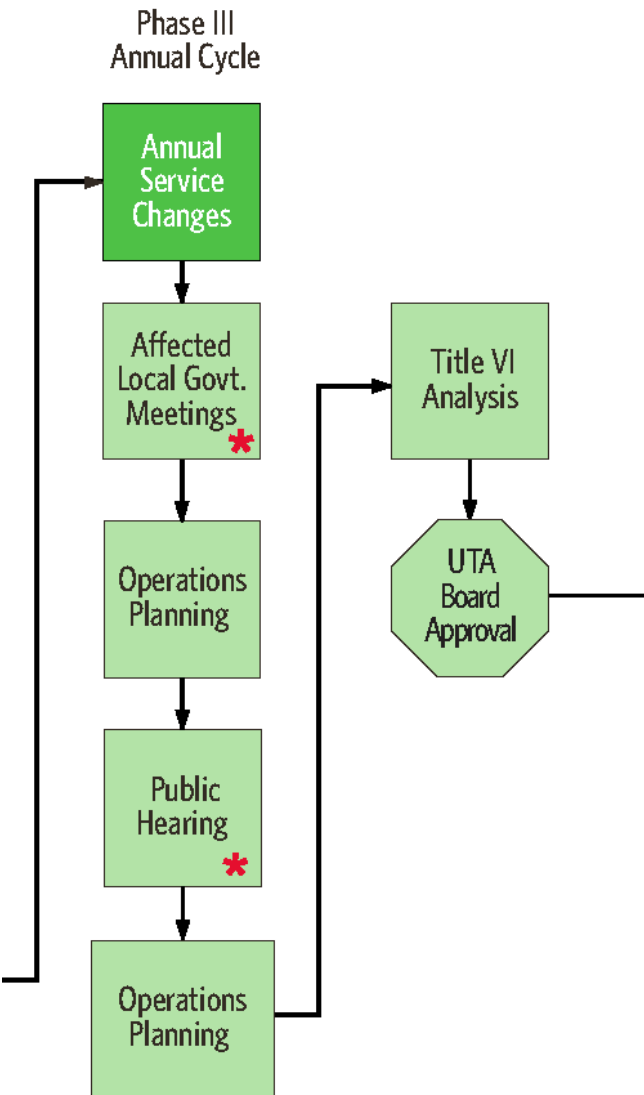

UTAH TRANSIT AUTHORITY



Phase 4 - Service Implementation

Implementation

UTAH TRANSIT AUTHORITY

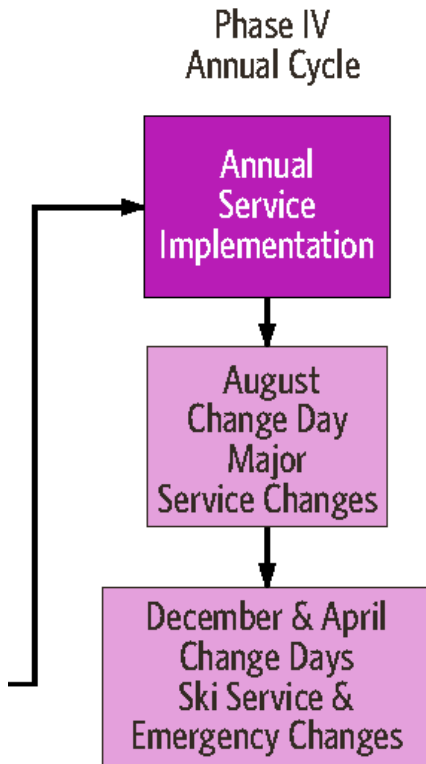

Service Planning Toolbox

1. Service Planning Policy
2. Service Planning Overview
3. Service Design Guidelines
4. Five-Year Mobility Plan
5. Bus Stop Master Plan
6. Comprehensive System Analysis

UTAH TRANSIT AUTHORITY



TOD System Analysis Tool and Criteria



All Metrics

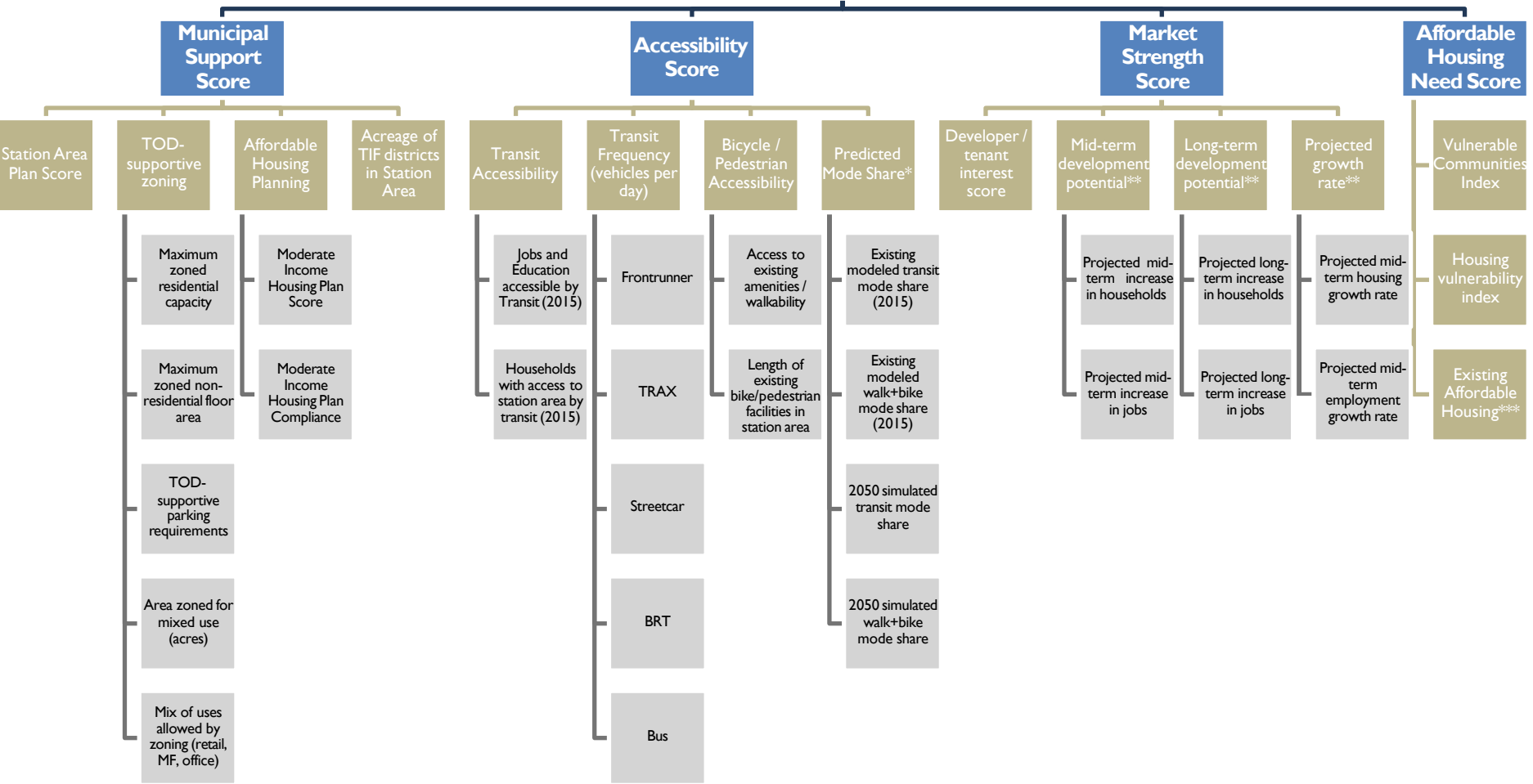

* Predicted Mode Share is based on a model developed by the University of Utah

** Development potential and projected growth rate is based on the REMM model developed by Wasatch Front Regional Council. Mid-term reflects 10-year growth based on existing zoning; long-term reflects growth to 2050 based on aspirational zoning.

*** In order to prioritize locations that do not already have a large supply of affordable housing, the indexed version of this variable is inverted so that locations with fewer units score higher.

This score captures station areas that “check all the boxes” and represent strong candidates for market-rate TOD investments.

Overall TOD Score

Municipal Support Score 33%

Accessibility Score 33%

Market Strength Score 33%

Affordable Housing Need Score

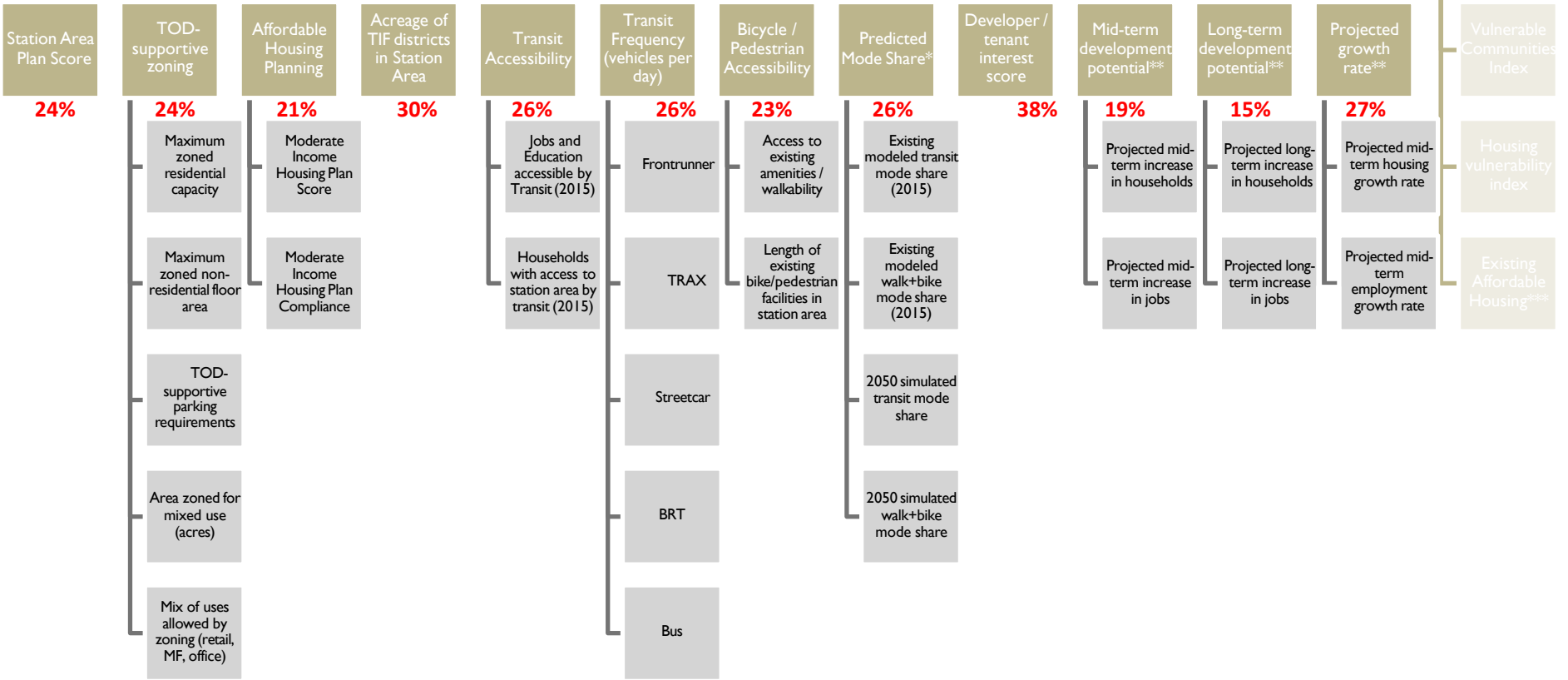

* Predicted Mode Share is based on a model developed by the University of Utah.
 ** Development potential and projected growth rate is based on the REMM model developed by Wasatch Front Regional Council. Mid-term reflects 10-year growth based on existing zoning; long-term reflects growth to 2050 based on aspirational zoning.
 *** In order to prioritize locations that do not already have a large supply of affordable housing, the indexed version of this variable is inverted so that locations with fewer units score higher.

This score captures station areas where there is significant growth potential but transit-oriented development patterns do not currently exist.

Growth Opportunity Site Score

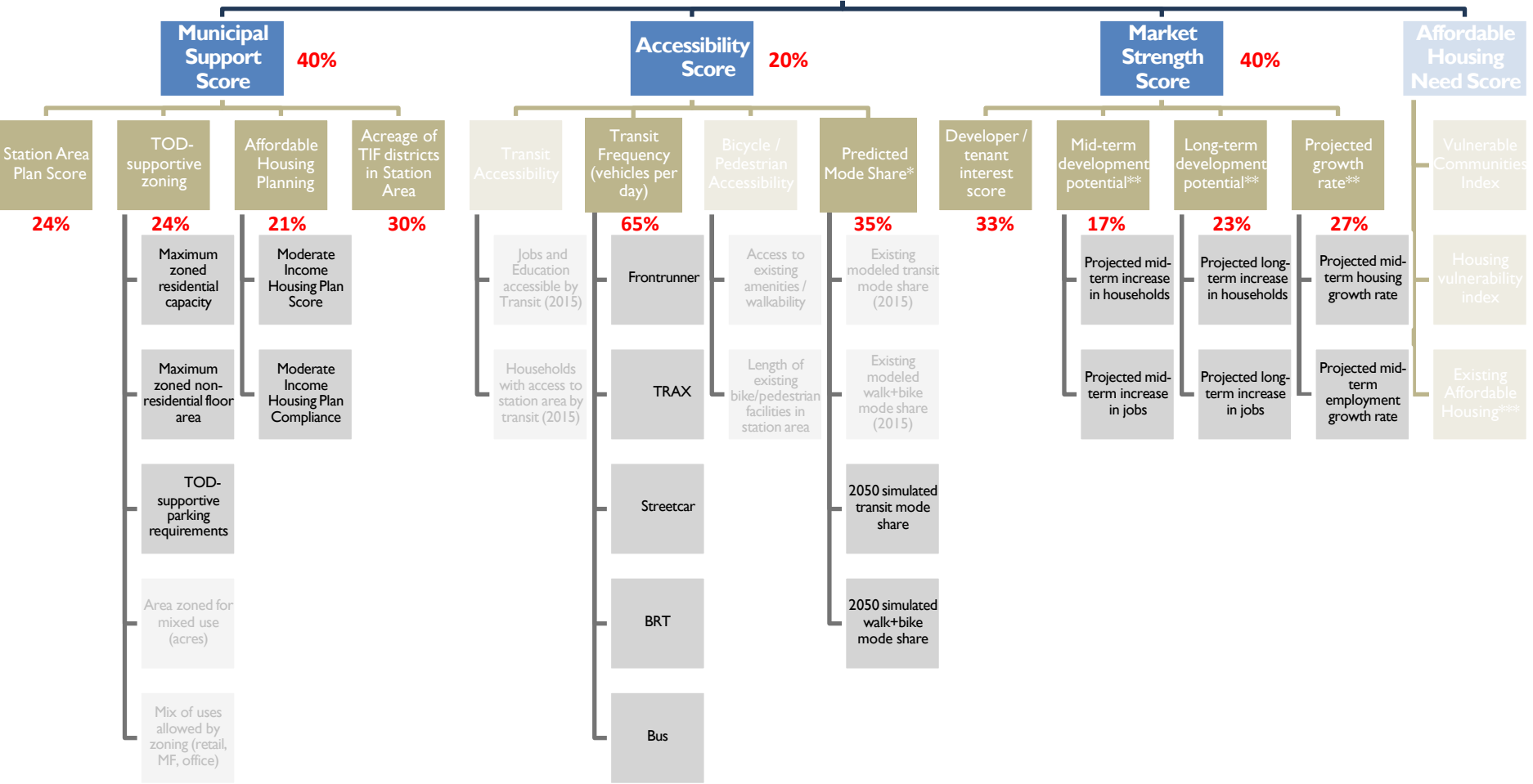

* Predicted Mode Share is based on a model developed by the University of Utah

** Development potential and projected growth rate is based on the REMM model developed by Wasatch Front Regional Council. Mid-term reflects 10-year growth based on existing zoning; long-term reflects growth to 2050 based on aspirational zoning.

*** In order to prioritize locations that do not already have a large supply of affordable housing, the indexed version of this variable is inverted so that locations with fewer units score higher.

This score captures station areas where an affordable housing TOD project would be most appropriate.

Affordable Housing Site Score

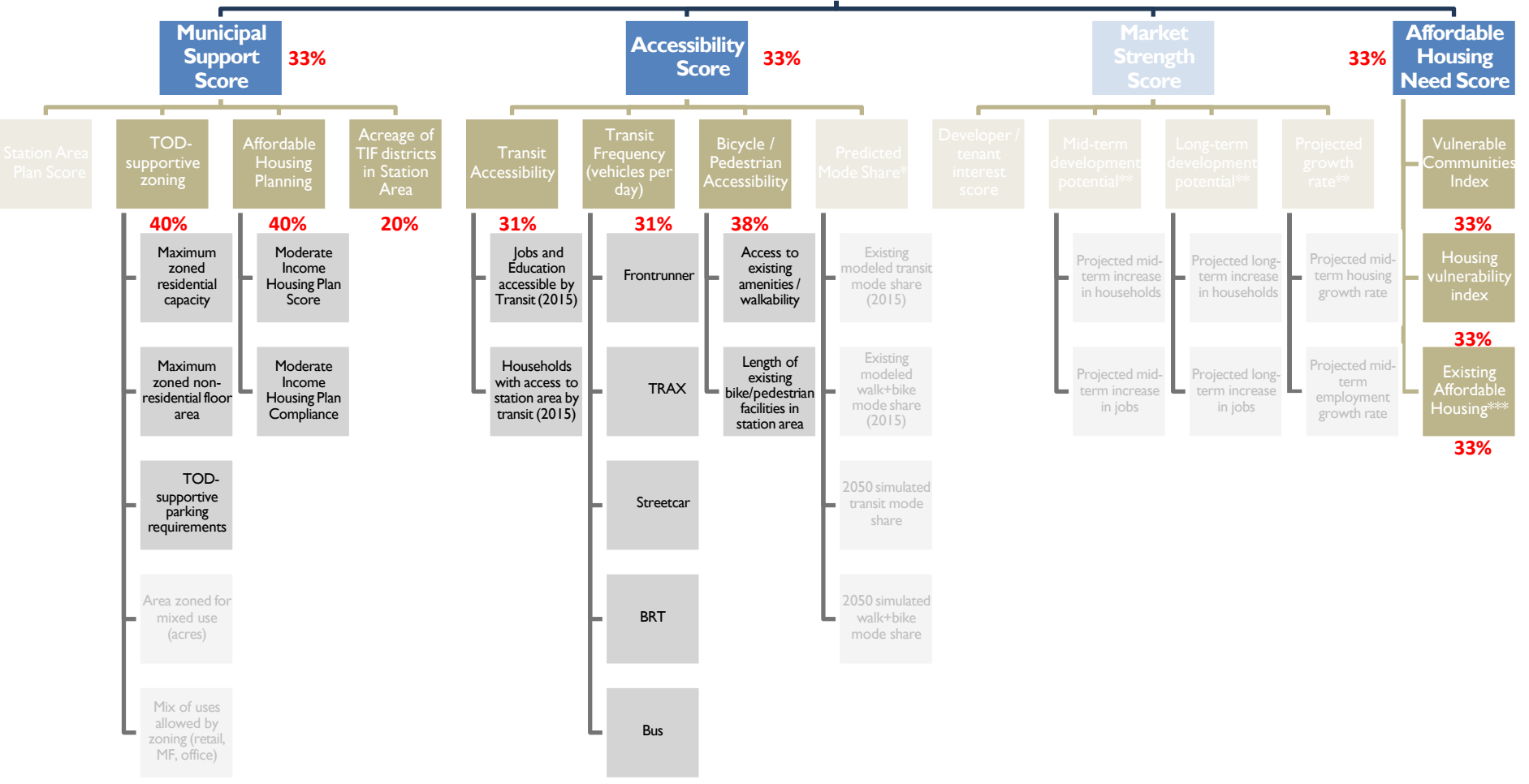

* Predicted Mode Share is based on a model developed by the University of Utah.

** Development potential and projected growth rate is based on the REMM model developed by Wasatch Front Regional Council. Mid-term reflects 10-year growth based on existing zoning; long-term reflects growth to 2050 based on aspirational zoning.

*** In order to prioritize locations that do not already have a large supply of affordable housing, the indexed version of this variable is inverted so that locations with fewer units score higher.

Ogden BRT Environmental Study

UTAH TRANSIT AUTHORITY





Ogden/Weber State University BRT

Project Update – Feb 2019

Project Partners



Project Purpose



- Develop a transportation solution that connects the Ogden FrontRunner Station with downtown, WSU and McKay-Dee
- Offer transportation choices for students, commuters and those who want improved service
- Improve and revitalize corridors
- Generate new economic development opportunities
- Improve air quality and congestion

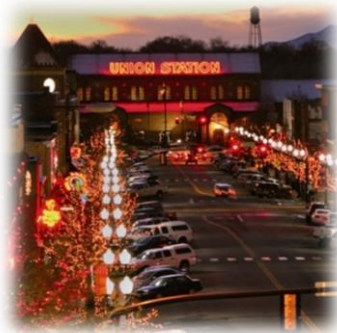

Project Development



Current Status of the Ogden/WSU BRT

UTA Capital Development Project Implementation Process

Planning

Development

Implementation

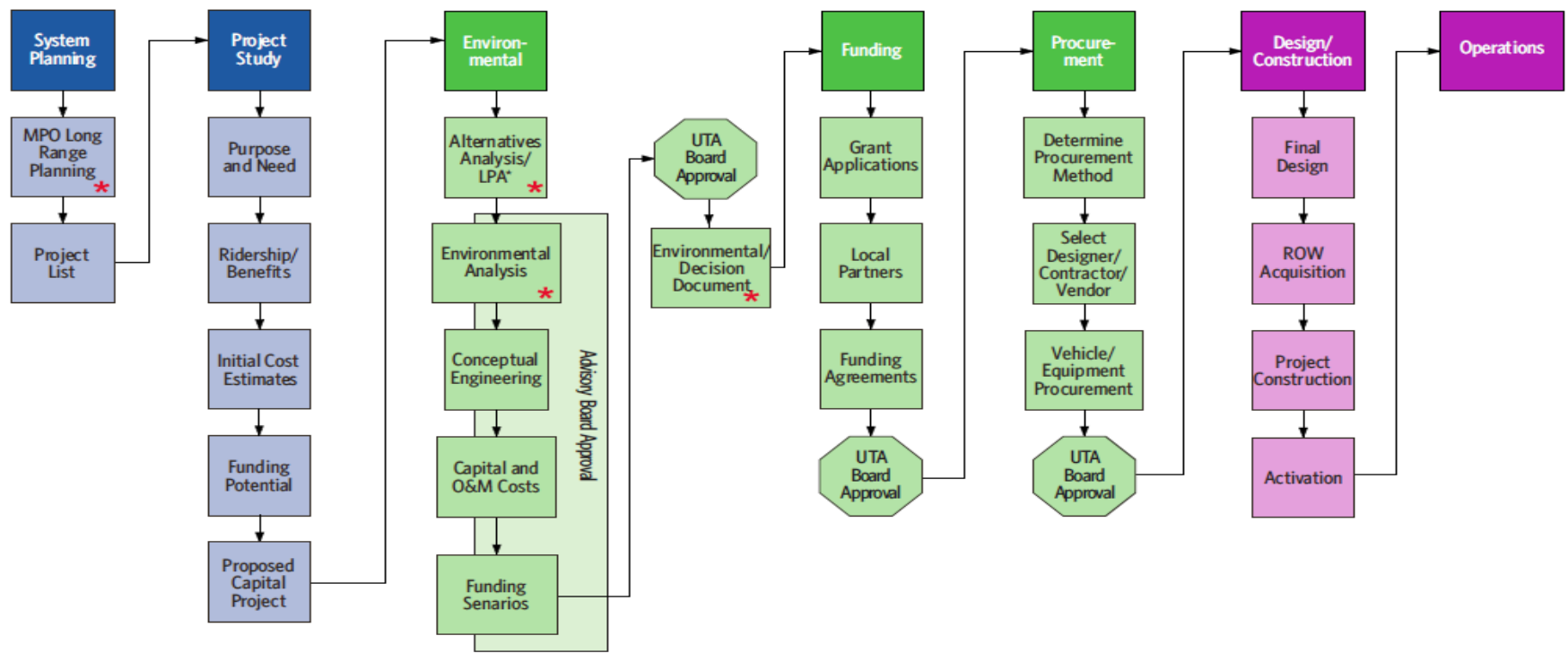

* Community Engagement Opportunity

Advisory Board Updates Throughout

Ogden/WSU BRT Project Summary



Ridership: 3,100 opening day + 3,000 new riders from existing Weber State shuttle

Capital Cost: \$79M

Annual Operation and Maintenance: \$1.7M total, \$700K added operations and maintenance over replaced bus route

Land Use: 25th Street is transit supportive with multiple land uses

Economic Development Potential: \$550 M

Project Funding/Federal Programs:

Assuming 65% local match

Up to \$25M in local funding is required \$23M has been committed

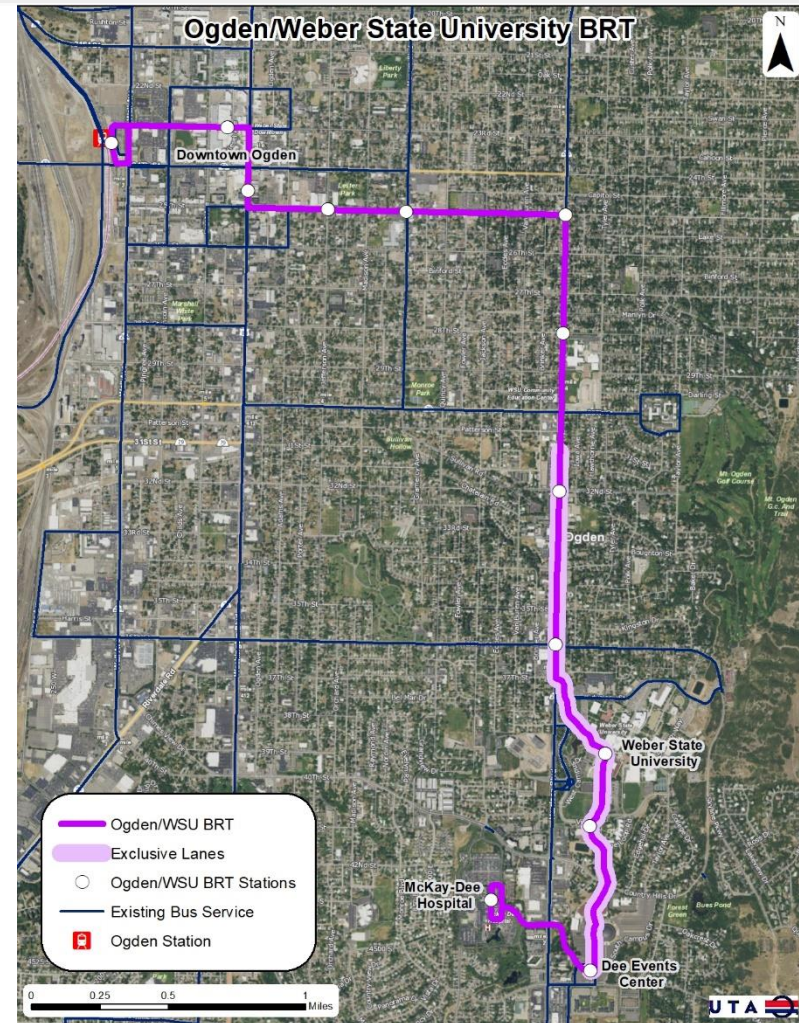

Current Efforts



- The Ogden/WSU BRT Environmental Assessment was recently completed
 - A public open house was held on January 9, 2019
 - 37 comments were received on the document
 - The final step is to receive a Finding of No Significant Impact (FONSI) from the Federal Transit Administration



- A request for proposals was issued last month to obtain a final design contractor
 - UTA expects to have a consultant onboard by April
- UTA submitted the project for Small Starts Capital Investment Grant last year
 - The Federal Transit Administration is currently reviewing the application

Project Budget



Ogden BRT Funding Plan	
Total Project Cost	\$ 79,000,000
Federal small starts request	\$ 49,750,000
Locally Programmed Funding	\$ 23,250,000
CMAQ/STP funding	\$ 6,000,000
Locally Programmed Funding	
Ogden (Design)	\$ 100,000
UDOT (Design)	\$ 50,000
WSU Land Donation	\$ 3,600,000
UTA (Design)	\$ 1,000,000
Weber County	\$ 1,250,000
Weber County	\$ 1,250,000
UTA	\$ 7,000,000
Weber County Corridor Preservation	\$ 5,000,000
Weber County Roadway funding	\$ 1,000,000
Ogden City	\$ 3,000,000

The project partners are seeking a Small Start Construction Grant

Project Schedule



**Ogden - Weber State University BRT
Draft Schedule**

Date: 8/22/2018

	2018												2019												2020												2021												2022												2023															
	J	F	M	A	M	J	J	A	S	O	N	D	J	F	M	A	M	J	J	A	S	O	N	D	J	F	M	A	M	J	J	A	S	O	N	D	J	F	M	A	M	J	J	A	S	O	N	D	J	F	M	A	M	J	J	A	S	O	N	D	J	F	M	A												
Environmental Assessment and Preliminary Engineering	█																																																																											
Request to Enter Project Development																																																																												
Right of Way Acquisition													█												█																																																			
Procure Consultant for Final Design													█												█																																																			
Final Civil and Systems Design																									█												█																																							
Small Starts Construction Grant Agreement																																					█																																							
Vehicle Build																																					█												█																											
Construction																																					█												█																											
Project Testing																																																	█												█															
Project Opens																																																																									█			

█ Expenditures █ Income █ Milestones

Other Business

- a. Next meeting: February 20, 2019 at 9:00 a.m.



Closed Session

- a. Strategy session to discuss pending or reasonably imminent litigation



Recommended Action (by acclamation)

Motion to go into closed session for a strategy session to discuss pending or reasonably imminent litigation



Closed Session



Open Session



Adjourn

